



Village Of South Blooming Grove

Incorporated on July 14, 2006

P.O. Box 295

Blooming Grove, New York 10914

STREET OPENING PERMIT APPLICATION

File number	DATE OF START OF WORK:	TYPE OF LOCATION (Commercial / Residential / Store / Office)	ADDRESS OF LOCATION OF STREET OPENING:
SECTION / BLOCK / LOT #:		APPLICATION FEE PAID:	PRE-CONSTRUCTION & PAVING FEE PAID:

OWNER / APPLICANT'S INFORMATION:

OWNER / APPLICANT'S SIGNATURE:	
PRINT:(Last Name / First):	
OWNER'S HOME ADDRESS:	OWNER'S HOME PHONE #
OWNER'S E-MAIL ADDRESS:	OWNER'S CELLPHONE #

CONTRACTOR'S INFORMATION:

NAME OF CONTRACTOR: (Last Name / First):	TITLE:
BUSINESS ADDRESS:	BUSINESS PHONE #
E-MAIL ADDRESS:	CELLPHONE #

CONTRACTOR'S CERTIFICATE OF INSURANCE INFORMATION: CERTIFICATE ON FILE Y N

NAME:	PHONE #
ADDRESS:	POLICY #:

REASON TO OPEN VILLAGE STREET: (CHECK ONLY ONES THAT APPLIES)

A) SEWER SERVICE REPAIR	YES <input type="checkbox"/> NO <input type="checkbox"/>	B) WATER SERVICE REPAIR	YES <input type="checkbox"/> NO <input type="checkbox"/>
C) NEW SEWER SERVICE HOOK-UP	YES <input type="checkbox"/> NO <input type="checkbox"/>	D) NEW WATER SERVICE HOOK-UP	YES <input type="checkbox"/> NO <input type="checkbox"/>
E) UTILITY ELECTRIC	YES <input type="checkbox"/> NO <input type="checkbox"/>	F) UTILITY GAS	YES <input type="checkbox"/> NO <input type="checkbox"/>
G) CABLE T.V.	YES <input type="checkbox"/> NO <input type="checkbox"/>	H) OTHER (EXPLAIN BELOW)	YES <input type="checkbox"/> NO <input type="checkbox"/>

OTHER TYPE:

NAME

INSPECTED BY:	Y <input type="checkbox"/> N <input type="checkbox"/>	INTERIM INSPECTION	Y <input type="checkbox"/> N <input type="checkbox"/>
INSPECTED BY:	Y <input type="checkbox"/> N <input type="checkbox"/>	PASSED INSPECTION	Y <input type="checkbox"/> N <input type="checkbox"/>
INSPECTED BY:	Y <input type="checkbox"/> N <input type="checkbox"/>	PASSED FINAL INSPECTION	Y <input type="checkbox"/> N <input type="checkbox"/>

PAVEMENT RESTORATION DEPOSIT \$1000.00

DEPOSIT WILL BE REFUNDED ONLY AFTER ALL INSPECTIONS ARE COMPLETED BY VILLAGE

NOTIFICATION AND COPIES SENT TO:

NAME	NOTIFIED	NAME	NOTIFIED
WATER DEPT:	Y <input type="checkbox"/> N <input type="checkbox"/>	SEWER DEPT:	Y <input type="checkbox"/> N <input type="checkbox"/>
VILLAGE ENGINEER:	Y <input type="checkbox"/> N <input type="checkbox"/>	BLDG DEPT:	Y <input type="checkbox"/> N <input type="checkbox"/>
VILLAGE CLERK:	Y <input type="checkbox"/> N <input type="checkbox"/>	OTHER:	Y <input type="checkbox"/> N <input type="checkbox"/>

PERMIT ISSUED:	Y <input type="checkbox"/> N <input type="checkbox"/>	PERMIT #:
----------------	---	-----------

The Owner/Contractor has received a copy of the Village Streets & Sidewalks Code (section 110) and has read and understands their obligation pertaining to the code and has affixed their signature to this form attesting to the

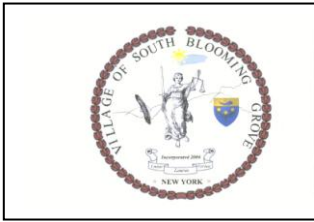

Village Of South Blooming Grove

Incorporated on July 14, 2006

P.O. Box 295

Blooming Grove, New York 10914

STREET OPENING PERMIT APPLICATION

TOTAL AMOUNT TO BE SUBMITTED BEFORE ISSUANCE OF PERMIT \$ _____

PAID BY: APPLICANT \$ _____ CONTRACTOR \$ _____

PLEASE NOTE:

1. All applications to be accompanied by Insurance Certificate of approved form and amount required by Municipal Law
2. All trench backfill to be "ROB" gravel. Item 4 to be used as road sub-base material, in compacted layers.
3. Immediate paving restoration to be a minimum of 4" of Item 51, Type 1A binder course (NYSDPW std.)
4. Final paving restoration to be a min of 2" of bituminous concrete surface, compacted, applied between 45 to 60 days after Item 4 above.
5. No deposit will be returned until all above items are completed, inspected and approved by the Highway Department and/or Village Engineer.

STREET OPENING APPROVED _____ DATE _____

INSPECTED AND RELEASE OF DEPOSIT DATE: _____

AUTHORIZED _____ TITLE _____

COMMENTS: Please see the attached Village's minimum "Trench Restoration Requirements" for all road openings.



Village Of South Blooming Grove

Incorporated on July 14, 2006

P.O. Box 295

Blooming Grove, New York 10914

STREET OPENING PERMIT APPLICATION

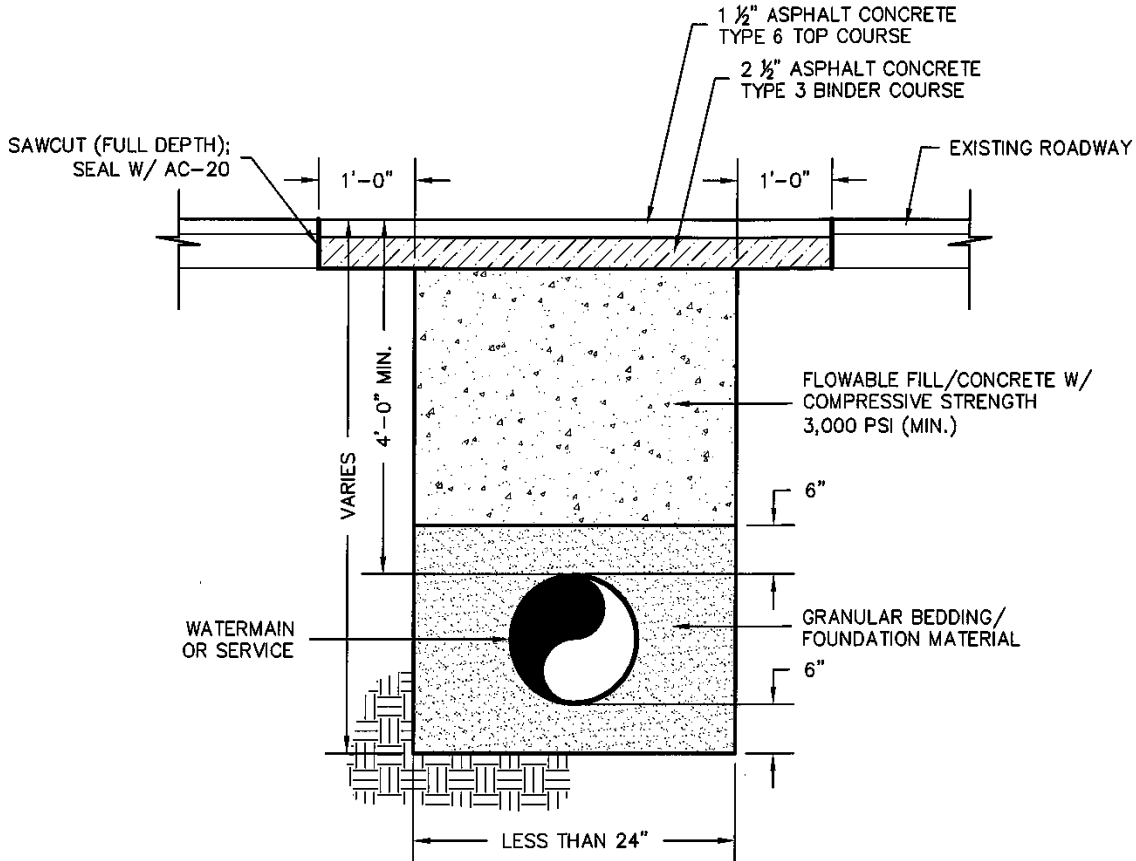

NOTES:

1. OPEN CUT METHOD MAY BE UTILIZED WITH THE PERMISSION OF THE VILLAGE ENGINEER.
2. IN CASES THAT REQUIRE TEMPORARY HARD SURFACE RESTORATION, 4 INCHES OF A DENSE BINDER MATERIAL SHALL BE INSTALLED. PERMANENT RESTORATION FOLLOWING THE ABOVE DETAIL SHALL BE COMPLETED WITHIN 6 MONTHS (MAXIMUM) OF THE TEMPORARY RESTORATION. REFER TO TEMPORARY RESTORATION DETAIL.
3. THE VILLAGE ENGINEER SHALL BE NOTIFIED PRIOR TO ANY CONSTRUCTION WITHIN THE VILLAGE ROADWAY OR RIGHT-OF-WAY.

3:2007/07-10 - South Blooming Grove/07-10 - General Engineering/TYPICAL DETAILS.dwg, DETAILS, 8/7/2013 4:48:42 PM

MHE **McGOEY, HAUSER and EDSALL**
CONSULTING ENGINEERS, P.C.

33 Airport Center Drive
New Windsor, New York 12553
(845) 567-3100

111 Wheelfield Drive, Suite 1
Milford, Pennsylvania 18337
(570) 286-2765

540 Broadway
Monticello, New York 12701
(845) 784-3391

Revision	Date	Description

VILLAGE OF SOUTH BLOOMING GROVE

Design: NORBERT
 Drawn: H.P.B., Jr.
 Checked: J.M.F.
 Scale: NONE
 Date: JUNE 2012
 Job No: 07-10

TYPICAL UTILITY TRENCH OPEN CUT NOT EXCEEDING 24" TEMPORARY RESTORATION

Sheet: 15
TEMP REST.



Village Of South Blooming Grove

Incorporated on July 14, 2006

P.O. Box 295

Blooming Grove, New York 10914

STREET OPENING PERMIT APPLICATION

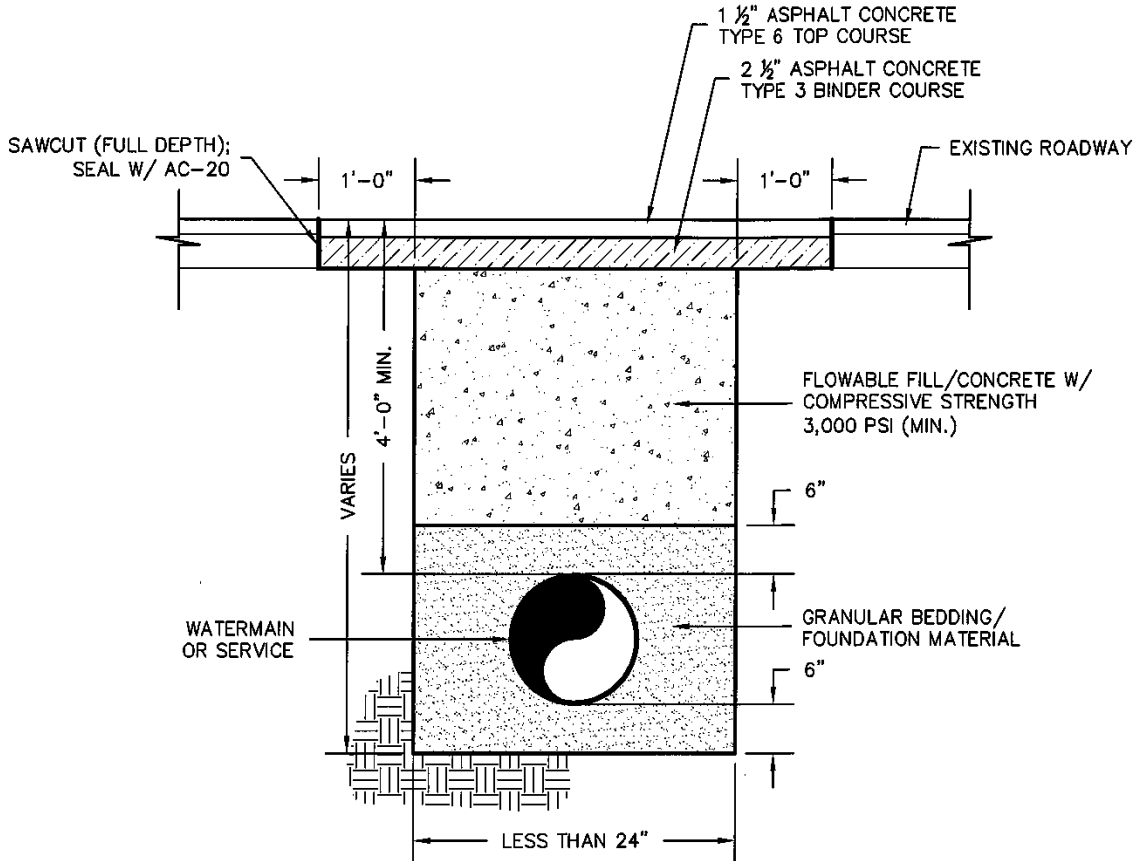

NOTES:

1. OPEN CUT METHOD MAY BE UTILIZED WITH THE PERMISSION OF THE VILLAGE ENGINEER.
2. IN CASES THAT REQUIRE TEMPORARY HARD SURFACE RESTORATION, 4 INCHES OF A DENSE BINDER MATERIAL SHALL BE INSTALLED. PERMANENT RESTORATION FOLLOWING THE ABOVE DETAIL SHALL BE COMPLETED WITHIN 6 MONTHS (MAXIMUM) OF THE TEMPORARY RESTORATION. REFER TO TEMPORARY RESTORATION DETAIL.
3. THE VILLAGE ENGINEER SHALL BE NOTIFIED PRIOR TO ANY CONSTRUCTION WITHIN THE VILLAGE ROADWAY OR RIGHT-OF-WAY.

MHE **McGOEY, HAUSER and EDSALL**
CONSULTING ENGINEERS, P.C.

33 Airport Center Drive
New Windsor, New York 12553
(845) 567-3100

111 Wheelfield Drive, Suite 1
Milford, Pennsylvania 18337
(570) 286-2765

540 Broadway
Monticello, New York 12701
(845) 764-3391

Revision	Date	Description

VILLAGE OF SOUTH BLOOMING GROVE

Design: NORBERT
 Drawn: H.P.B., Jr.
 Checked: J.M.F.
 Scale: NONE
 Date: JUNE 2012
 Job No: 07-10

**TYPICAL UTILITY TRENCH
 OPEN CUT NOT EXCEEDING 24"
 TEMPORARY RESTORATION**

Sheet: 15

**TEMP
 REST.**

2:2007/07-10 - South Blooming Grove07-10 - General Engineering\TYPICAL DETAILS.dwg, 8/7/2013 4:48:42 PM